

Part #10043

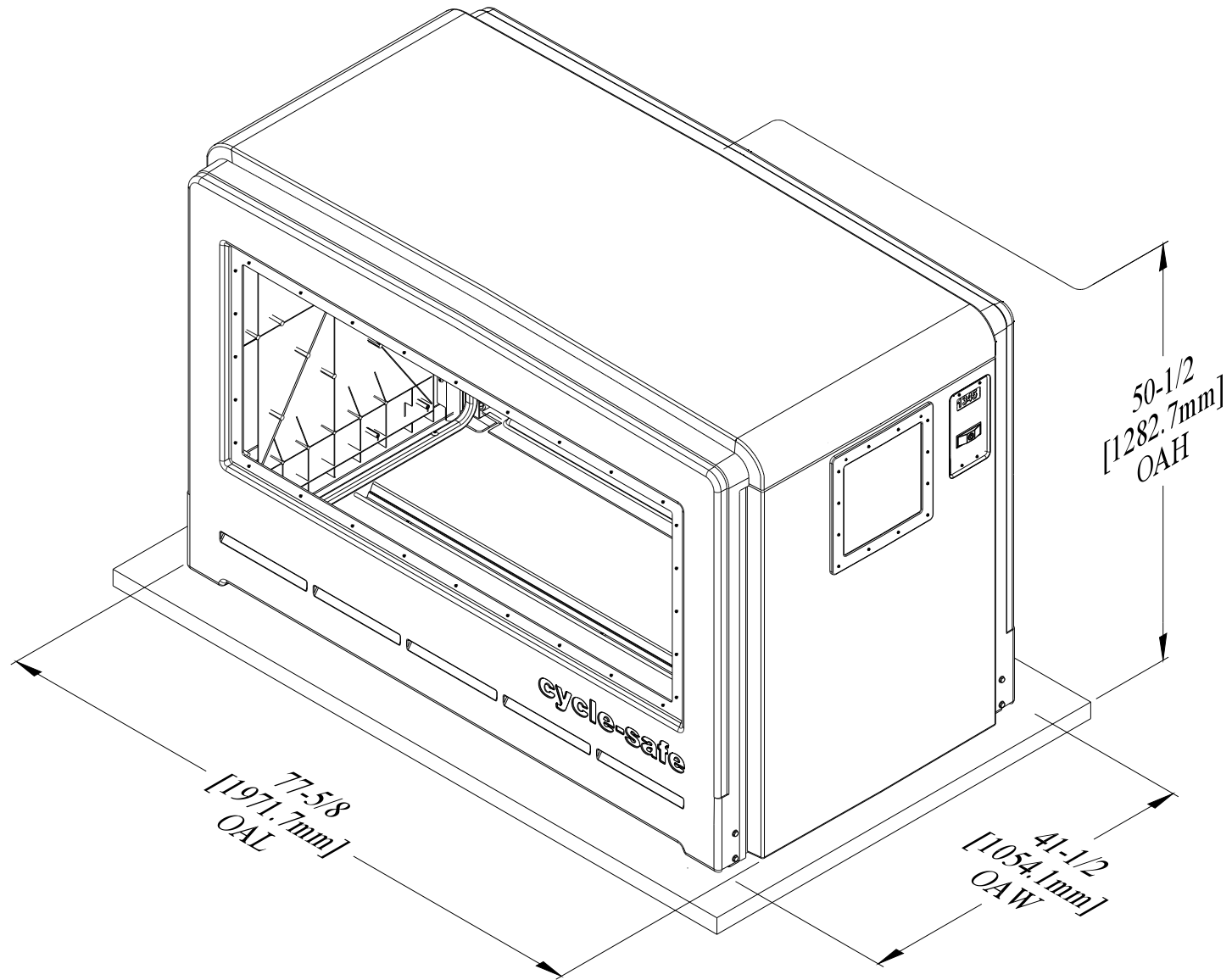

ProPark VT {S01}
{1-Bike} Starter Locker {Dims}

Starter #10043
Adder #10045

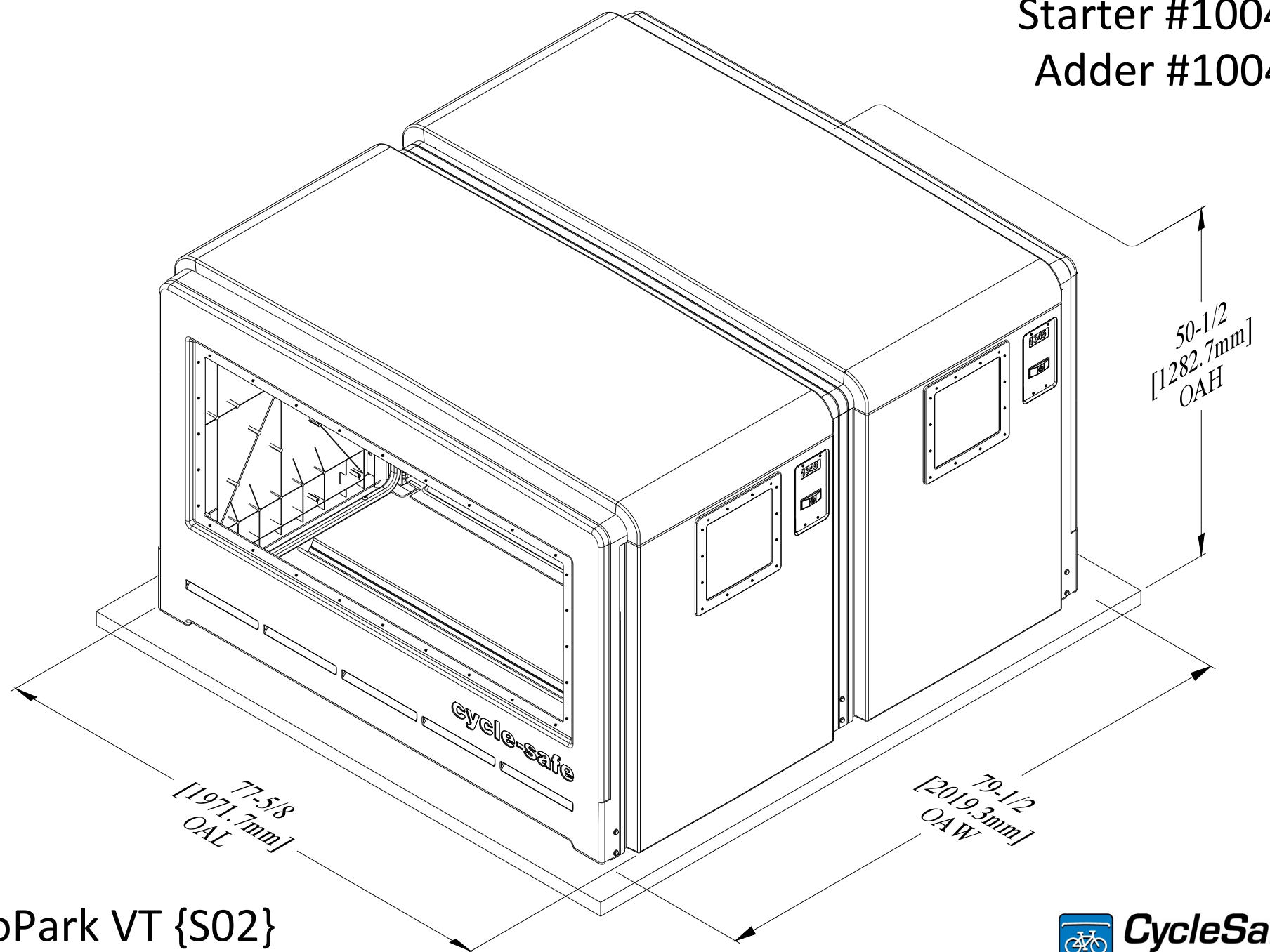

ProPark VT {S02}
{2-Bike} Locker Assy {Dims}

Part #10007

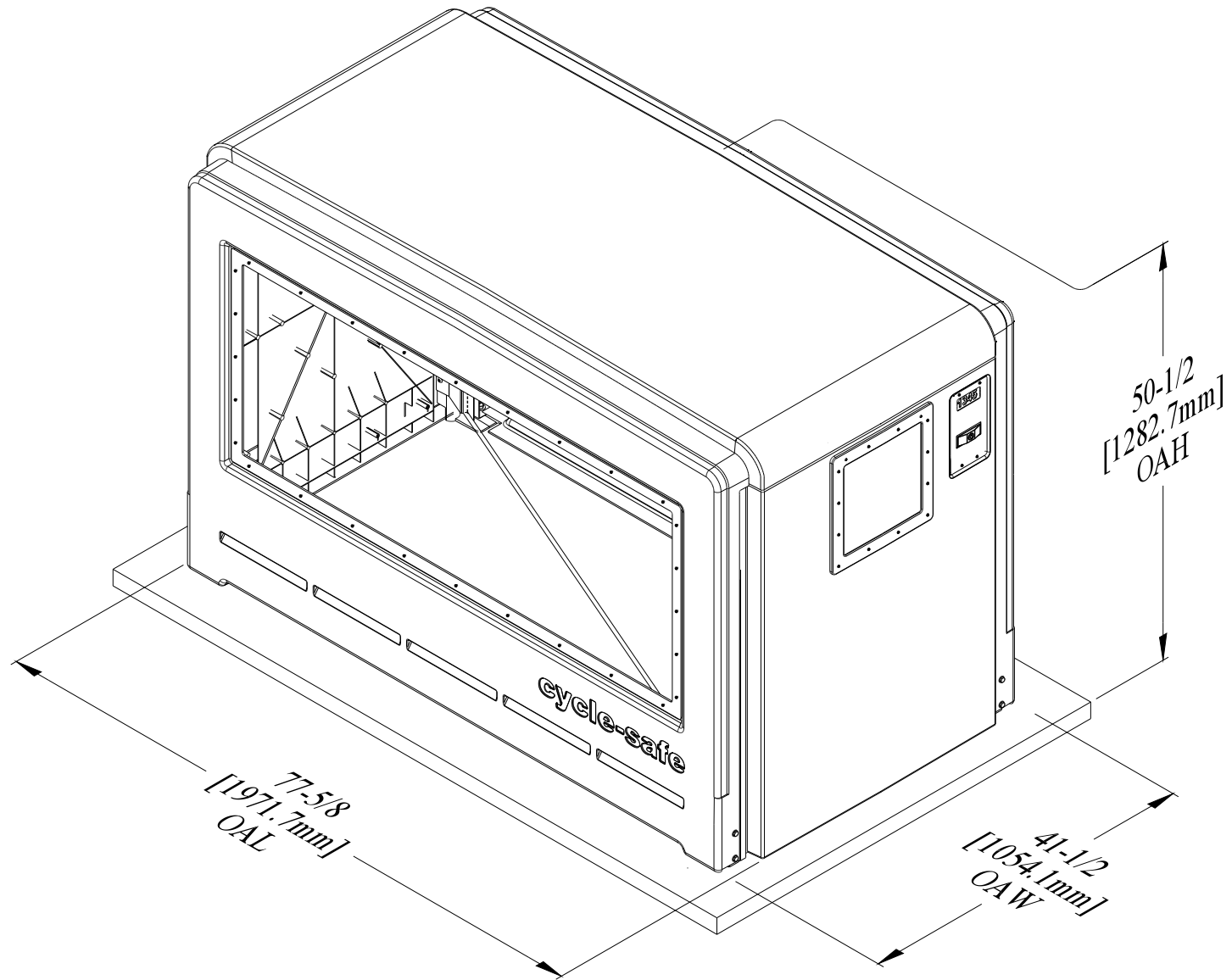

ProPark VT {M02}
{2-Bike} Starter Locker {Dims}

Starter #10007
Adder #10056

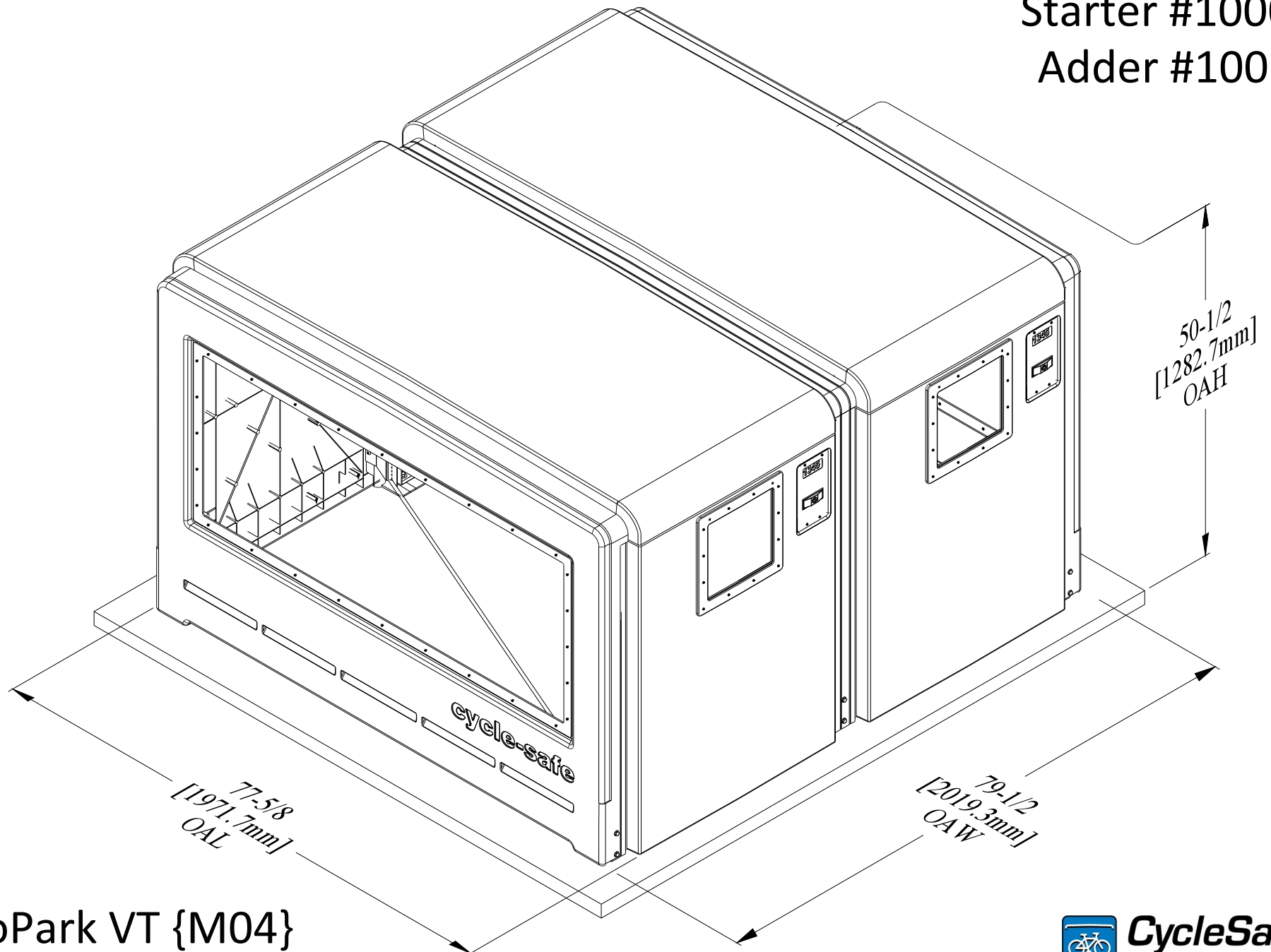

ProPark VT {M04}
{4-Bike} Locker Assy {Dims}



www.cyclesafe.com

NOTE:

INCLINE ANGLES

A. DOOR-TO-DOOR INCLINE TO BE NO MORE THAN 1 ° SLANT

B. BANKING SIDE-TO-SIDE TO BE NO MORE THAN 2 ° SLANT

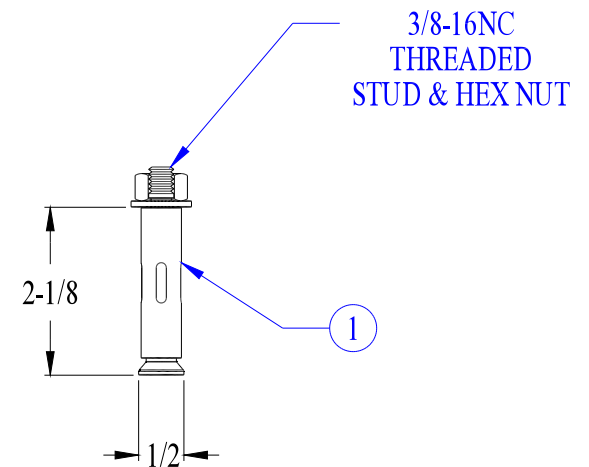
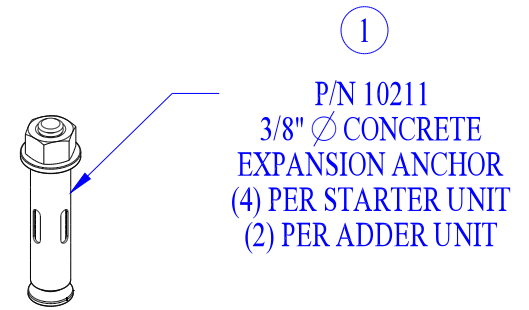
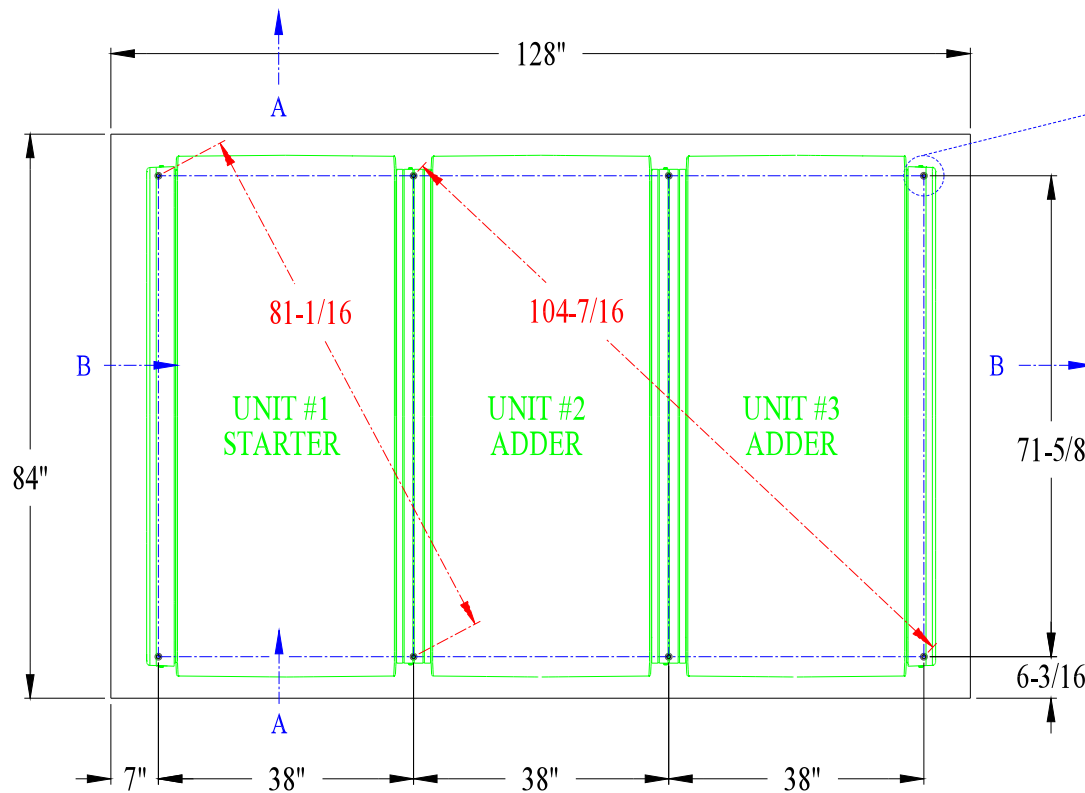

ProPark {M06} Lockers Anchor Placement Locations



www.cyclesafe.com

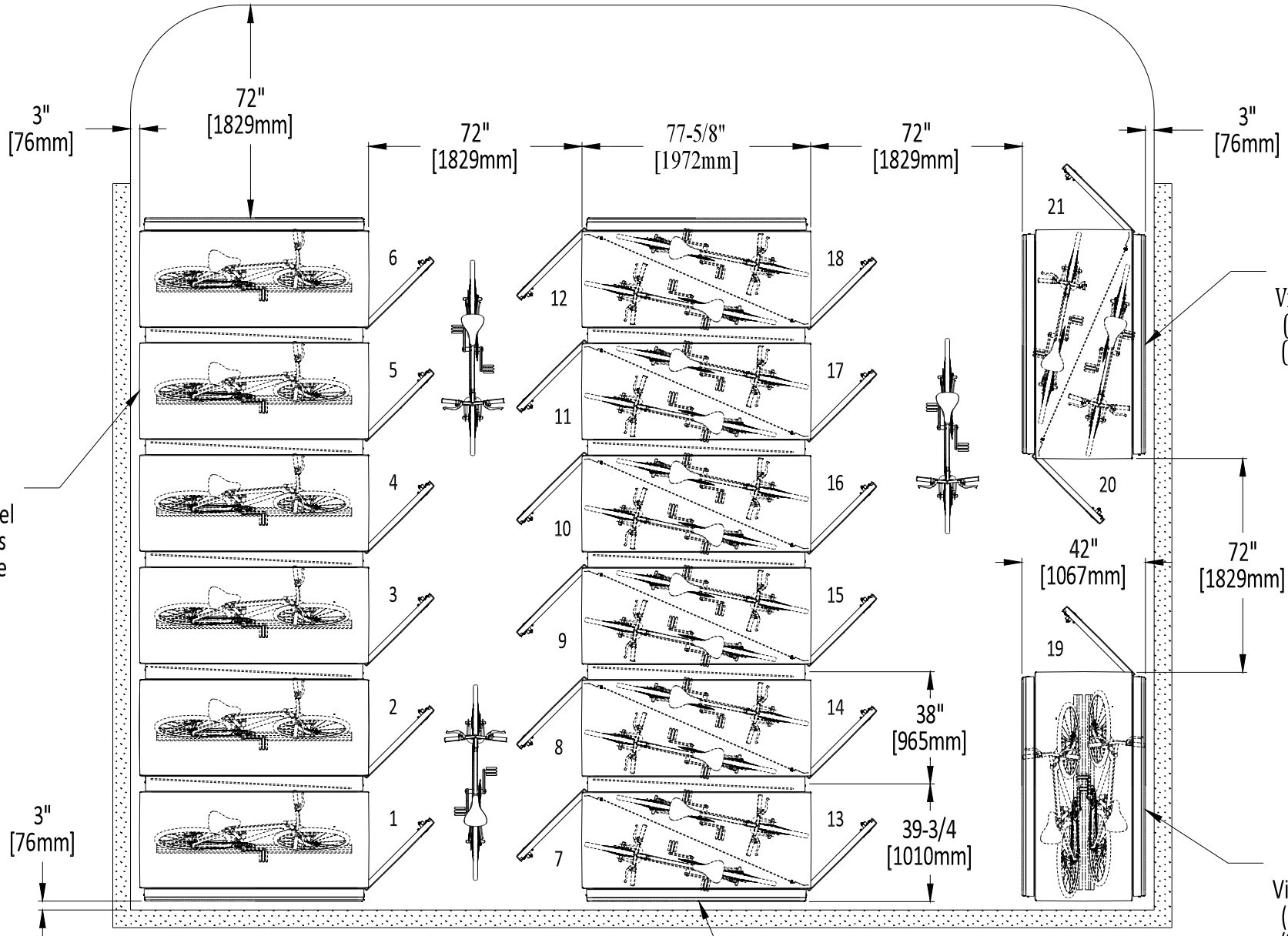

VT-S06
View-Thru Model
(1) Door Access
(1) Bike Storage

VT-M02
View-Thru Model
(2) Door Access
(2) Bike Storage

VT-S01
View-Thru Model
(1) Door Access
(2) Bike Storage

VT-M12
View-Thru Model
(2) Door Access
(12) Bike Storage

ProPark {Locker} Layout Clearances & Capacities



www.cyclesafe.com